



# Data Sheet

010.D.981.04

## Analog Meters for clamping to DIN Rails

**W 35**  
**P 35**  
**LSP 35**



**WEIGEL**

## Application

The analog meters **W 35**, **P 35**, **LSP 35** designed for clamping to DIN rails are used for the measurement of current and voltage in distribution installations which utilize 35 mm DIN rails according to DIN EN 60 715 for equipment mounting.

The mounting width of 52.5 mm is equal to 3 sectional units.

The meters can also be surface mounted besides clamping to a DIN rail.

## Functional Principle

**W 35** moving-iron movement with shell-type system, silicon oil damping and spring loaded jewel bearings, pivot suspension.

**P 35** moving-coil movement with core-type magnetic system, dual spring loaded jewel bearings, pivot suspension.

**LSP 35** moving-coil movement with swivel-coil system, dual spring loaded jewel bearings, pivot suspension.

## Mechanical Data

case details	projecting case clamping to 35 mm mounting rail complying with DIN EN 60 715		
material of case	thermoplastics, self-extinguishing		
colour of case	W 35, P 35 gray (similar to RAL 7032) LSP 35 gray (similar to RAL 7035)		
material of window	polycarbonate		
position of use	vertical $\pm 5^\circ$		
terminals	screw terminals (up to 5 mm <sup>2</sup> )		
dimensions LxWxH	W 35, P 35	75 mm x 52,5 mm x 68 mm	
	LSP 35	95 mm x 52.5 mm x 63 mm	
weight approx.	W 35	P 35	LSP 35
	0.1 kg	0.1 kg	0.2 kg

## Electrical Data

measuring unit	W 35	AC voltage or AC current	
	P 35	DC voltage or DC current	
	LSP 35	DC voltage or DC current	
overload capacity (acc. to DIN EN 60 051 - 1)	continuously 1.2 times rated voltage / current		
	5 s max.		
voltmeters	2 times rated voltage		
ammeters	10 times rated current		
power consumption W 35			
voltmeters	approx. 1.5 ... 3 VA		
ammeters	approx. 0.5 ... 1 VA		
frequency range W 35	45 ... 65 Hz		
enclosure code	IP 52 case front side IP 00 for terminals without protection against accidental contact IP 20 for terminals protected against accidental contact		
measurement category	CAT III		
operating voltage	W 35	P 35	LSP 35
	600 V	300 V	150 V
pollution level	2		

◆ also refer to "Options"

## Measuring Ranges

### For mains use

AC current	W 35	AC voltage	W 35
1 A		100 V	
1.5 A		150 V	
2.5 A		250 V	
4 A		400 V	
5 A		500 V	
6 A			
10 A			
15 A			
25 A			
◆			
<b>for use on current transformer 1)</b>		<b>for use on voltage transformer 2)</b>	
N/1 A		100 V sec.	
N/5 A		110 V sec.	

Please state transformer ratio when ordering.

1) full-scale value = 2 times rated current (overload scaling) ◆

2) full-scale value = 1.2 times rated voltage ( – " – )

DC current	internal resistance <sup>3)</sup> / voltage drop approx.		DC voltage >5V sensitivity <sup>3)</sup>		
	P 35	LSP 35	P 35	LSP 35	
1 mA	60 mV	270 $\Omega$	10 V	1000 $\Omega/V$	1000 $\Omega/V$
6 mA	60 mV	60 mV	40 V	1000 $\Omega/V$	1000 $\Omega/V$
20 mA	60 mV	60 mV			
1 A	60 mV	60 mV			
1.5 A	60 mV	60 mV			
2.5 A	60 mV	60 mV			
4 A	60 mV	60 mV			
6 A	60 mV	60 mV			
◆					
<b>for use with external shunt</b>			sensitivity <sup>3)</sup>		
			<b>P 35</b>	<b>LSP 35</b>	

60 mV	1000 $\Omega/V$	200 $\Omega/V$
150 mV	1000 $\Omega/V$	200 $\Omega/V$

a total lead resistance of 0.05  $\Omega$  is considered in the calibration of the indicator for connecting leads 1 m, 2 x 0.75 mm<sup>2</sup>

### Not for mains use

	DC voltage $\leq 5V$ sensitivity <sup>3)</sup>		
	P 35	LSP 35	
	1 V	1000 $\Omega/V$	1000 $\Omega/V$
	1.5 V	1000 $\Omega/V$	1000 $\Omega/V$
	2.5 V	1000 $\Omega/V$	1000 $\Omega/V$
	4 V	1000 $\Omega/V$	1000 $\Omega/V$

<sup>3)</sup> the resistance values are limited to a tolerance of  $\pm 20\%$



## Analog Meters for clamping to DIN Rails

### Scaling

pointer	W 35, P 35 LSP 35	bar / knife-edge pointer bold bar pointer
dial	LSP 35	platform dial
pointer deflection	W 35                      P 35                      LSP 35 0 ... 90°                      0 ... 90°                      0 ... 240°	
scale characteristics	W 35                      P 35                      LSP 35 initial scale compressed, calibrated down to 1/5 th of rated full-scale value linear	
scale division		coarse-fine
scale length	W 35                      P 35                      LSP 35 35 mm                      35 mm                      68 mm	
overload scaling	W 35 ammeters	2 times rated current ↗
	voltmeters for use on voltage transformers	1.2 times rated voltage

### Accuracy at Reference Conditions

accuracy class	1.5 according to DIN EN 60 051 - 1
<b>reference conditions</b>	
ambient temperature	23°C
position of use	nominal position ± 1°
input quantity	rated measuring value
frequency	W 35 45 ... 65 Hz
wave form	W 35 sinusoidal, distortion factor <5%
others	DIN EN 60 051 - 1

#### influences

ambient temperature	23°C ± 2K
position of use	nominal position ± 5°
frequency	W 35 15 ... 100 Hz (voltage) 15 ... 400 Hz (current)
stray magnetic field	0.5 mT

### Environmental

climatic suitability	climatic class 2 according to VDE/VDI 3540, sheet 2
operating temperature range	-25 ... +40°C
storage temperature range	-25 ... +65°C
relative humidity	≤ 75% annual average, non-condensing
shock resistance	15 g, 11 ms
vibration resistance	2.5 g, 5 ... 55 Hz

### Rules and Standards

DIN 43 802	Line scales and pointers for indicating electrical measuring instruments; general requirements
DIN 16 257	Nominal positions and position symbols used for measuring instruments
DIN EN 60 051	Direct acting indicating analogue electrical measuring instruments and their accessories
-1	Part 1: Definitions and general requirements common to all parts
-2	Part 2: Special requirements for ammeters and voltmeters
-9	Part 9: Recommended test methods

DIN EN 60 529	Enclosure codes by housings (IP-code)
DIN EN 60 715	Dimensions of low voltage switching devices: standardized DIN rails for mechanical fixation of electrical devices in switchgears
DIN EN 61 010 - 1	Safety requirements for electrical measuring, control and laboratory equipment Part 1: General requirements
DIN EN 61 326 - 1	Electrical equipment for measurement, control and laboratory use – EMC requirements Part 1: General requirements
VDE/VDI 3540 sheet 2	reliability of measuring and control equipment (classification of climates)

### Options

#### measuring range

special measuring range	deviating from standard
-------------------------	-------------------------

#### dial

blank dial	pencil marked initial and end values
scale division and figuring	0 ... 100%, linear, full-scale values acc. to DIN series (1 – 1.5 – 2.5 – 4 – 6 and any decimal multiple of these numbers e.g. 150 m <sup>3</sup> /h) or deviating from DIN series; special calibration from customer's non-linear graph or chart; scaling of voltmeters in ohms; captions optional
P 35, LSP 35	

additional lettering	to be specified e.g. "generator"
additional figuring	to be specified
coloured marks	red, green or blue for important scale values
coloured sector	red, green or blue within scale division
logo on the dial	none or to be specified
overload scaling W 35	no overload range

### Dimensions and Terminals

#### W 35 / P 35

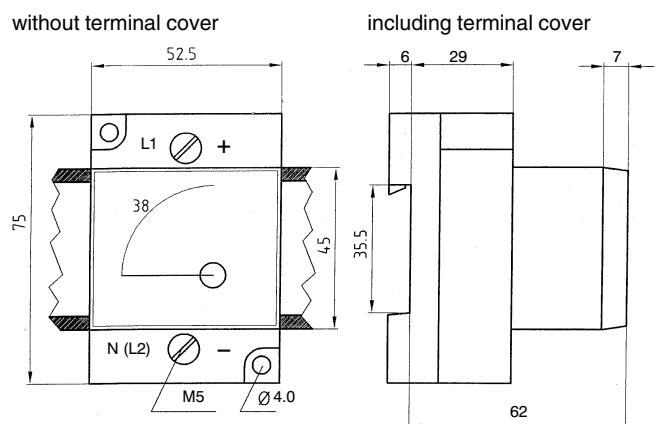

(dimensions in mm)

## LSP 35

without terminal cover

including terminal cover

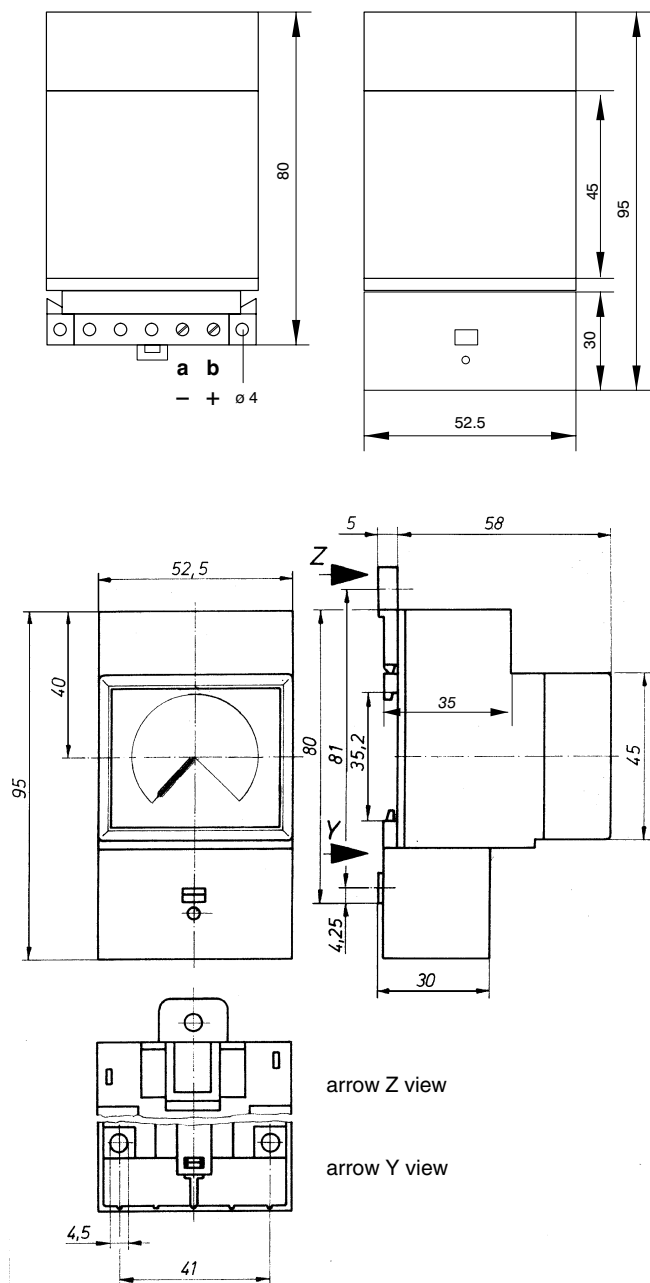

(dimensions in mm)

## Ordering Information

<b>type</b>	analog instrument clamping to DIN rail
<b>W 35</b>	for AC voltage or AC current, 90°
<b>P 35</b>	for DC voltage or DC current, 90°
<b>LSP 35</b>	for DC voltage or DC current, 240°
<b>measuring ranges</b>	refer to preceding table
<b>special measuring range</b>	to special order <sup>2)</sup>
<b>dial</b>	scale division and measuring range alike resp. full-scale values acc. to DIN series 1 – 1.5 – 2.5 – 4 – 6 <sup>1)</sup> blank dial scale division and figuring 0 ... 100% <sup>3)</sup> linear acc. to DIN series <sup>2)</sup> <sup>3)</sup> linear deviating from DIN series <sup>2)</sup> <sup>3)</sup> calibration fr. non-linear graph or chart <sup>2)</sup> scaling in ohms for voltmeters <sup>2)</sup> additional lettering to be specified <sup>2)</sup> additional figuring to be specified <sup>2)</sup> coloured marks red, green or blue <sup>2)</sup> coloured sector red, green or blue <sup>2)</sup>
<b>logo on the dial</b>	WEIGEL <sup>1)</sup> none OEM logo <sup>2)</sup>
<b>overload scaling</b>	none W 35 ammeters 2 times rated current <sup>1)</sup>

<sup>1)</sup> Standard

<sup>2)</sup> Please clearly add the desired specifications.

<sup>3)</sup> P 35, LSP 35 only

### ordering example

P 35, measuring range and scaling 0 ... 1 A

## Weigel Meßgeräte GmbH

Postfach 720 154 • 90241 Nürnberg • Phone: 0911/42347-0

Erlenstraße 14 • 90441 Nürnberg • Fax: 0911/42347-39

Sales: Phone: 0911/42347-94

Internet: <http://www.weigel-messgeraete.de>

e-mail: [vertrieb@weigel-messgeraete.de](mailto:vertrieb@weigel-messgeraete.de)

– specifications subject to change without notice; date of issue 12/10 –

